



ID Gate 7700

Date: January 2026

Version: ID Gate 7700



Please read and follow the installation instructions before operating the device and keep the instructions for future reference or for use after troubleshooting.

Content

1. Product Instruction	3
1.1 Note.....	3
1.2 Functional features	3
1.3 Technical parameter.....	4
1.4 Technical parameter.....	4
2. Product Structure and Working Principle	5
2.1 Installation notes & suggestion.....	5
2.2 Tripod turnstile electric control system	5
2.3 Operating principle of the system.....	6
3. Installation Instructions.....	7
3.1 Installation notes & suggestion:.....	7
3.2 Turnstile cable drawing	9
3.3 Turnstile circuit board wiring diagram	9
4. Menu Parameter Setting	10
4.1 Button introduction.....	10
4.2 Menu setting.....	10
4.3 Parameter setting instruction	10
5. Product Maintenance.....	12
5.1 Daily maintenance	12
5.2 Tips and troubleshooting.....	12
6. Support.....	15

1. Product Instruction

1.1 Note

- Before installation, operation or maintenance, please turn off the power.
- Please do not change the inside wiring, take a photo before any disconnection.
- Do not use the power supply inside the turnstile to connect another third-party device.
- The turnstile should not be operated during thunderstorms or lightning strikes, as this may damage the electrical parts of the turnstile.

1.2 Functional features

- Compact and cost-effective security solutions
- Stainless-steel body
- Turnstile with a standard open/close relay signal, which can be integrated with any type of third-party access control system. (e.g.: RFID, QR-Code and barcode reader).
- In case of an emergency, the turnstile will automatically open and allows for free passage.
- Anti-tailing function: only one person passes at a time.
- Anti-impact function: The rotating rod will lock automatically when the opening signal is not received.
- Automatic reset function: turnstile arm will lock automatically within 5s if passengers enter too late.
- Working way: Single directional or Bi-directional
- LED indicator (red means no entry; green means entry; blue means normal close)
- Easy to install and maintain

1.3 Technical parameter

The ID Gate 7700 is made of 304 stainless steel which is robust, rigid, anti-rust, waterproof and durable, it is ideal for both indoor and outdoor settings.

Appearance and dimensions are as shown in figure 1:

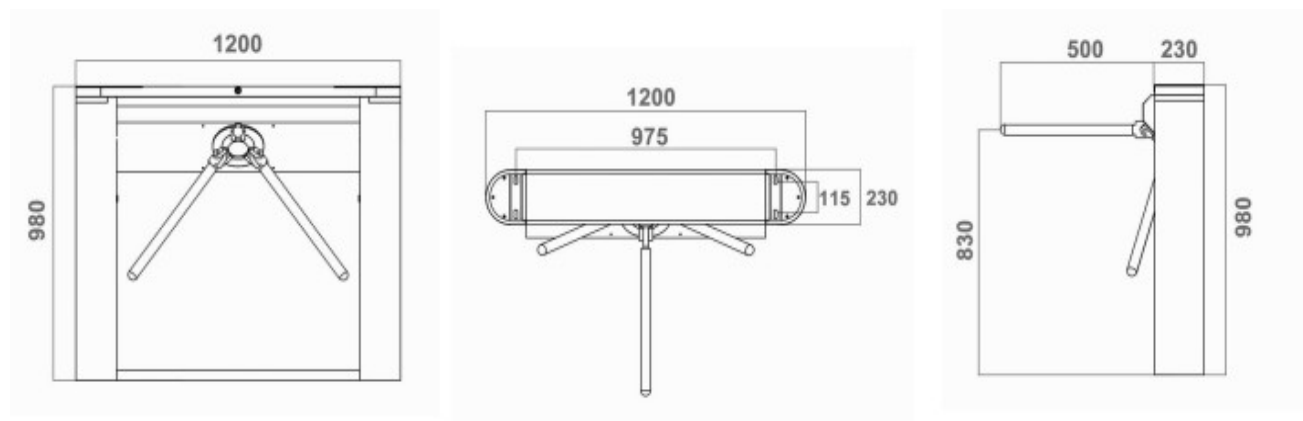

Figure 1

1.4 Technical parameter

Item	Description
Frame	304 Stainless Steel with rubber seal
Dimension	L1200*W230*H980(mm)
Weight	50Kg
Pass Width	1 lane, 550mm (Arm length: 500mm)
Power supply	AC230V/110V, 50/60Hz
Working voltage	24V DC
Emergency	Arms will drop down automatically
Power consumption	20W
Working environment	Indoors or outdoors, IP65
Working temperature	-15 °C - 60 °C
Humidity	0 ~ 95% (no freeze)
Control interface	Dry contact/Relay signal
Opening time	0.2 seconds
Passing speed	35~40 persons/min

2. Product Structure and Working Principle

2.1 Installation notes & suggestion

The turnstile's mechanical system is divided into a frame and a movable part. The frame includes direction indicators and read-write device. The main components of the movements are the motor, the motor frame, the drive shaft and the arms.

Movement structure

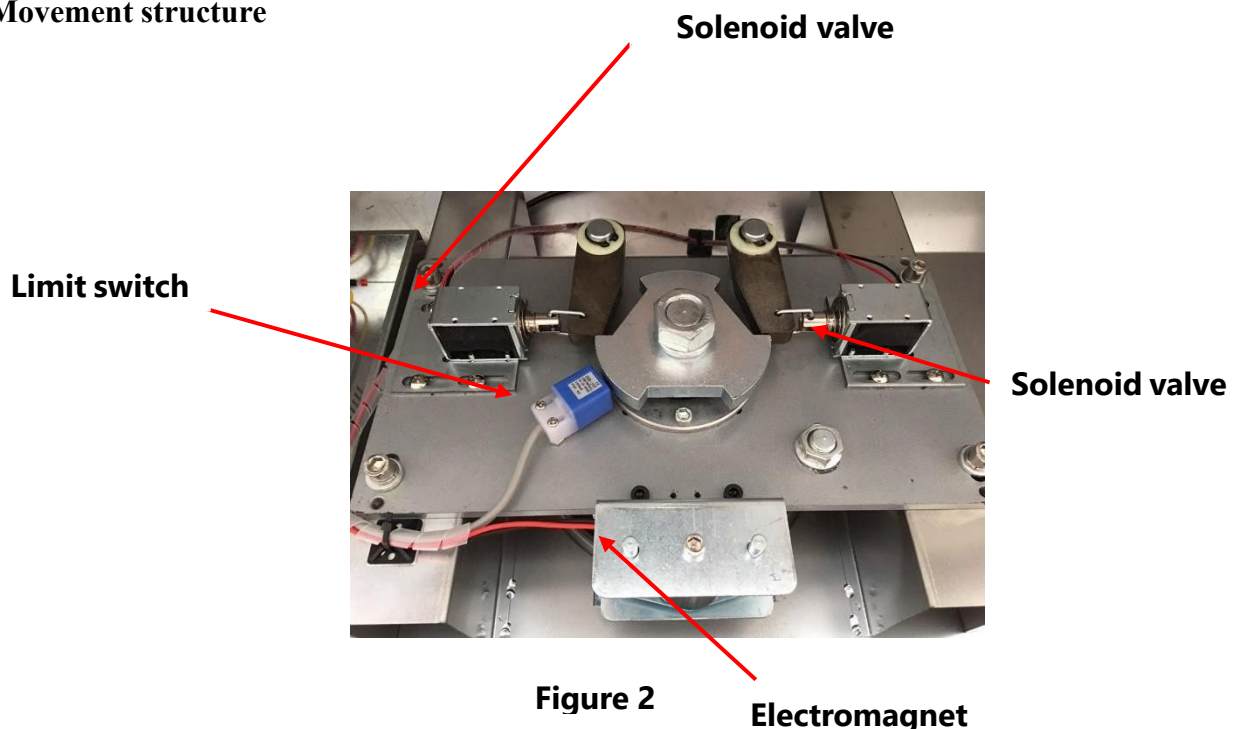

Figure 2

Electromagnet

2.2 Tripod turnstile electric control system

The electronic control system consists of card reader, main control board, direction indicator board, transformer and so on.

- **Card reader (self-provided):** After reading the card's information and processing the information, the card reader will send an application pass signal (switch signal) to the main control board.
- **Main control board:** The system's control, which receives the signals from the card reader, processes these signals and then issues execution commands to the flashing light, the motor, the counter and the alarm.
- **Direction indicator light:** Display the status of the passage signs and guide pedestrians through

the gate in a safe and orderly manner.

Item No.	NAME	FUNCTION
1	Entrance access system	IC/ID card access control, 1/2D barcode reader, gate opening signal on the control board of gate machine, remote control, button to open the gate(optional)
2	Control board	The system's control, which receives the signals from the card reader, processes these signals and then issues execution commands to the flashing light, motor, counter and alarm.
3	Direction indicator	The directional indicator light shows the status of the passage sign and guides pedestrians through the gate
4	Limit switch	Check opening and closing position
5	Switch	Supply power to control board

2.3 Operating principle of the system

- a) After 3 seconds, the system will enter working state if you turn on the power.
- b) When the card reader detects a valid card, the loudspeaker emits a sound indicating that the card has been read successfully. Furthermore, it evaluates and processes the information read from the card and sends an approval signal to the main controller.
- c) The main control receives the signals from the card reader. After thorough processing, it sends effective control signals to the direction indicator and motor, so that the direction indicator sign turns into the green arrow pass sign.
- d) After the pedestrian passes through the gate according to the direction indicator, the infrared sensor senses the entire process of the pedestrian passing through the gate and continuously sends signals to the main control panel until the pedestrian has passed through the gate completely.
- e) If a pedestrian forgets to read his card or reads an invalid card and enters the gate, the system will forbid the pedestrian to pass through. Rereading a valid card allows passage.

3. Installation Instructions

3.1 Installation notes & suggestion:

Note: During installation and construction, relevant circuits should be completely disconnected.

Please check all connections and correct installation before applying power.

- 1) It is recommended to lay the cables 60 mm deep, at least 50 mm, into the ground.
- 2) If the turnstiles are installed outdoors, it is recommended that they be secured with 100-200 mm deep anchors in concrete.
- 3) All operations should be carried out with the power off.
- 4) Power cable and normal electric cable are carried in a 3/4" PVC pipe and buried in cement in the appropriate place.
- 5) After adjusting the foundation area, place the devices in the correct order.
- 6) After the hole's position has been determined, drill the holes, and insert the anchor bolt or expansion screw M12.

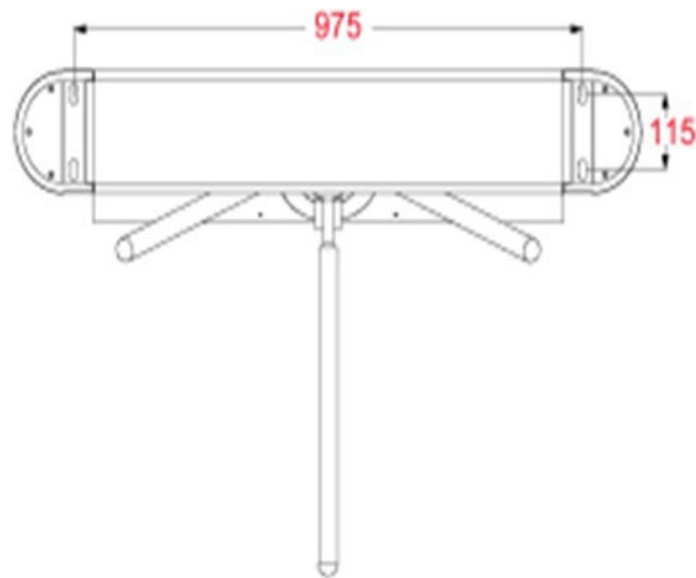

Figure 3

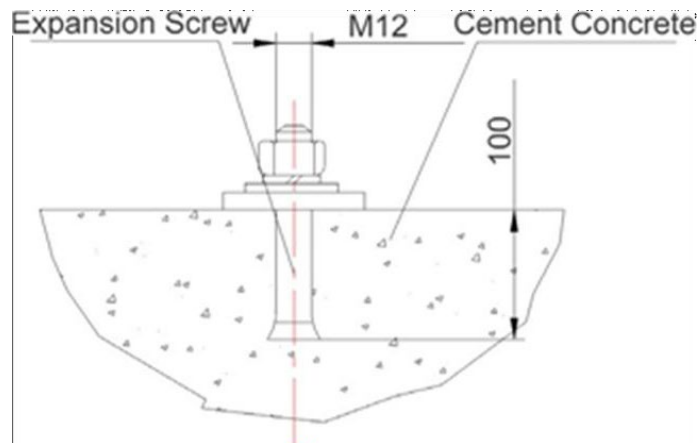

Figure 4

- 7) Open the casing, select one of the units as a reference (preferably the middle one), align the hole of the bottom screw with the corresponding anchor screw and pre-tighten the nut.
- 8) Connect the power line and the control line according to the wiring diagram and connect the ground cable to the system.
- 9) Check the main wiring according to the wiring diagram, check that the power wiring and other wiring of the entire unit are correct, and then adjust the power after confirmation.
- 10) After the installation is complete, check the connection condition of the earth wire, connector assembly for the connecting line and all moving parts with the device. Make sure the connection is firm in order to prevent failure caused by long time operation. If any screw or part is not tightened, please tighten.
- 11) After the check of the unit status has proceeded normally, the function can be tested.

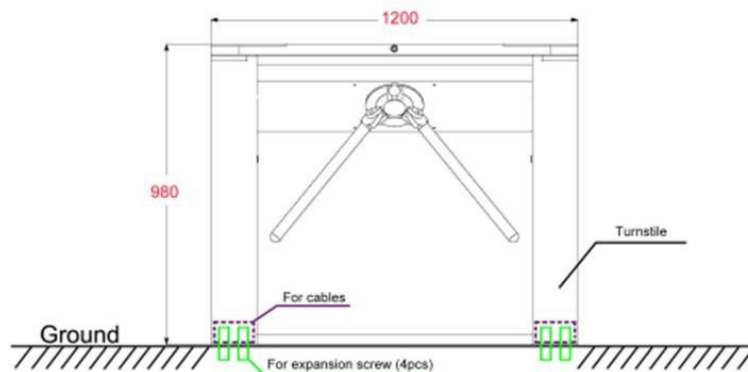

Figure 5

3.2 Turnstile cable drawing

— Power Cable
— Network Cable

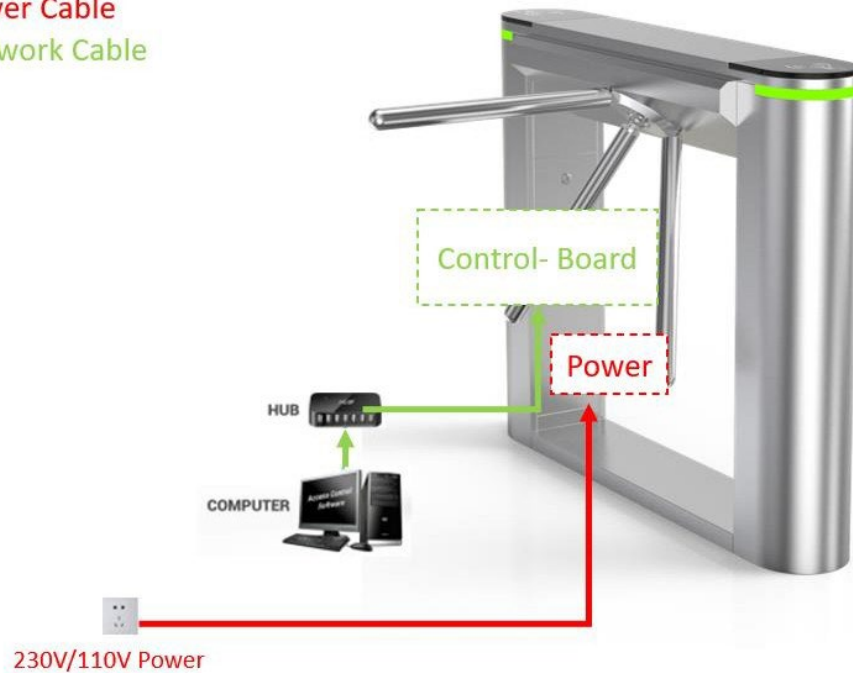

Figure 6

3.3 Turnstile circuit board wiring diagram

*Connect the turnstile to a 110V/230V power supply.

*Any type of third-party access control device can be connected to the "OP-L," "COM" and "OP-R" terminals.

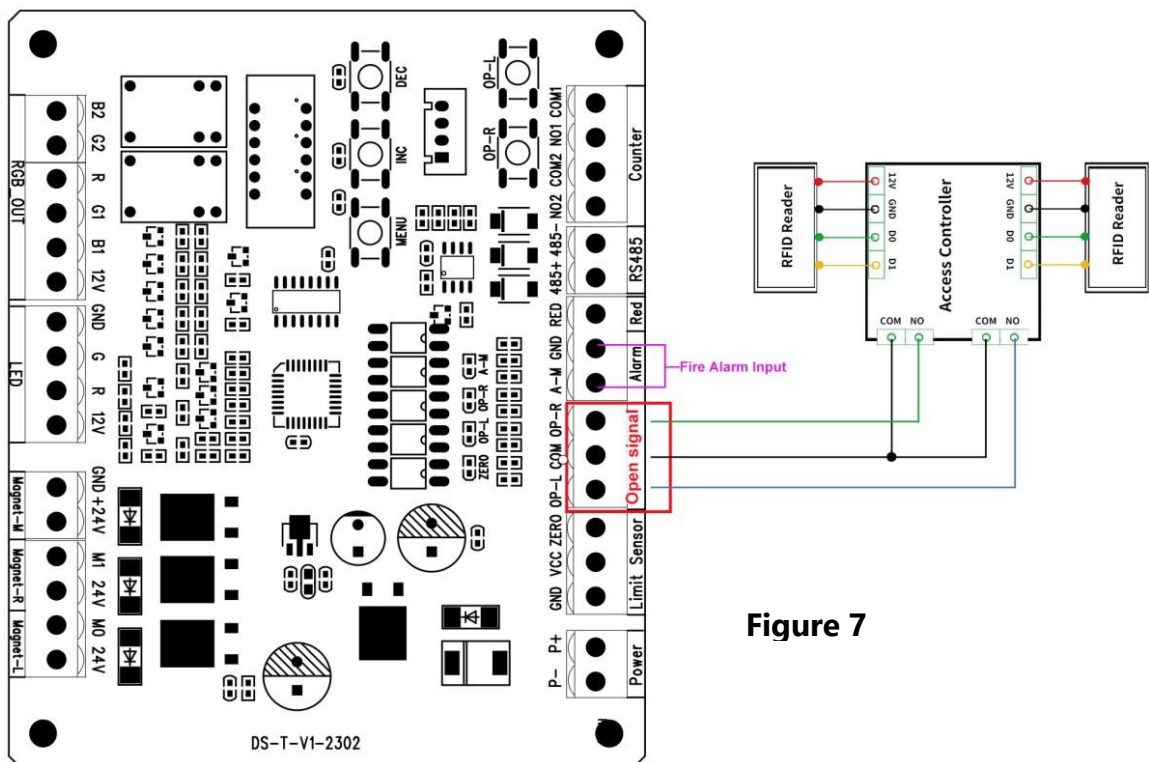

Figure 7

4. Menu Parameter Setting

4.1 Button introduction

The control board has three operation buttons: "MENU" menu key/confirm key, "INC" up/add key, and "DEC" down/subtract key.

"MENU" key:

1. In standby mode, it acts as a menu key. Long press this key to enter the menu.
2. In the menu interface, it acts as a confirm key. After selecting the corresponding menu, press this key to enter the menu parameter setting interface.
3. After the menu is set, press this key to save the parameters and return to the system menu interface. **"INC" key:** It increases the value by 1 when selecting the system menu and setting parameters. **"DEC" key:** It decreases the value by 1 when selecting the system menu and setting parameters.

Note: In the system menu and menu setting interface, if there is no button operation within 5 seconds, the system will automatically exit the menu to the standby interface.

4.2 Menu setting

For example, if you want to change the gate channel passage time:

Step 1: Long press the "MENU" key to enter the system menu, use the "INC" and "DEC" keys to select the "F 0 X" menu (menu explanation below).

Step 2: Press the "MENU" key to enter the channel time setting interface.

Step 3: Use the "INC" and "DEC" keys to increase or decrease the parameter value.

Step 4: After setting is complete, press the "MENU" key to save.

Step 5: Exit the menu: Select the "F 11" menu and press the "MENU" key to manually exit the menu or automatically exit the menu if there is no button operation within 5 seconds.

4.3 Parameter setting instruction

Control board connected to power, LED display shows <Run>

"F01" Set the passage time:

The time is automatically cleared to zero after the person passes through the gate within the set time. If no one passes through, the gate will automatically close when the time is up. (Default 5 seconds)

"F02": Constant open function setting.

1: Open the left electromagnet when it is always open. 2: Open the right electromagnet when it is always open.

3: Open both left and right electromagnets when they are always open. (Default value 3, open both electromagnets when it is always open)

"F03": Gate working mode.

0: Free passage (commonly used for turnstile); 1: Power-off drop bar (default 1 power-off drop bar)

"F04": Memory function.

Turn on or off the memory function of the opening signal input. Generally used for card swiping to open the gate. If there is one person swiping the card and has not passed through, whether to remember the card swiping of other people. "Prohibited" means that the second person's card swiping is effective only after the first person has passed through; "allowed" means that the number of people swiping the card is allowed to pass through continuously. (Default value 0, memory prohibited)

"F05": Repeatedly switch the gate test, mainly used to test the stability of the gate control board and aging test. Note: In the test mode, press the MENU key to exit the test.

"F06": Zero signal setting.

0: Close the gate immediately when the zero signal is detected (standard mode for three-roller gates, the main board is set to 0 by default);

1: Detect the zero signals, and then wait for the zero signals to disappear before closing the gate (commonly used for full-height gates) (default value 0)

"F07": Gate constant open setting the unit is seconds.

This parameter is used to detect continuous opening signals. When the duration of the continuous opening signal exceeds the parameter set, the system enters the constant open state (which electromagnet is always open is determined by the F02 parameter. The default value of F02 is that both electromagnets are always open). If the opening signal given to the gate is a continuous signal, the gate will remain open. After the continuous signal is disconnected, the gate will return to the standard mode. (Default parameter 0 seconds, constant open is closed)

"F08": Gate opening delay.

This parameter is effective only when the memory function is turned on. When there are too many people passing through continuously, this function can prevent the gate from opening again when the previous person has not passed through the channel. (default value 0, no delay)

"F09": Limit count setting.

Set how many times the limit signal needs to be detected during the gate opening process to close the gate. (default 1 time)

"F10": Restore factory settings.

All parameters of the main board are restored to the factory settings.

"F11": Exit the menu. Or automatically exit if there is no button operation within 5 seconds.

Note: In free passage mode, whether to count depends on the F02 parameter. When the F02 parameter is 1, the left free passage is counted, when the F02 parameter is 2, the right free passage is counted, and when the parameter is 3, the free passage is not counted.

5. Product Maintenance

5.1 Daily maintenance

- To avoid the risk of electric shock, always switch off the unit before inspecting it.
- Check the appliance at regular intervals to ensure that all parts are working properly.
- The material is stainless steel, do not use hard materials for cleaning.
- Clean fingerprints or stubborn stains with soapy water or alcohol, rinse with clean water and wipe dry if necessary.

5.2 Tips and troubleshooting

A. Tripod turnstile stays closed after a card has been swiped

- a) Check whether the main board receives the opening signal.
- b) Check whether the opening signal lead or the solenoid valve lead is loose.
- c) Measure with a multimeter whether there is a voltage of 24 V on the solenoid valve terminal of the main board and assess whether the solenoid valve is damaged.

B. Tripod turnstile arms do not fall down in case of power failure

a) Check if the support of the electromagnet is loose, readjust it and fix it.

C. When the arm is connected to the power supply, it cannot be lifted manually.

a) Check if the pole drops support of the electromagnet is loose, test if the electromagnet is magnetic with a metal object.

b) Use a multimeter to measure whether there is 24V at the electromagnet terminal of the main board, and assess whether the main board has normal voltage output.

D. The main board is not supplied with power after switching on

a) Check with a multimeter to check whether there is 24V voltage input at the input port.

b) Check whether the fuse has blown

c) Check whether there is 24V at the output end and assess whether the power supply is damaged

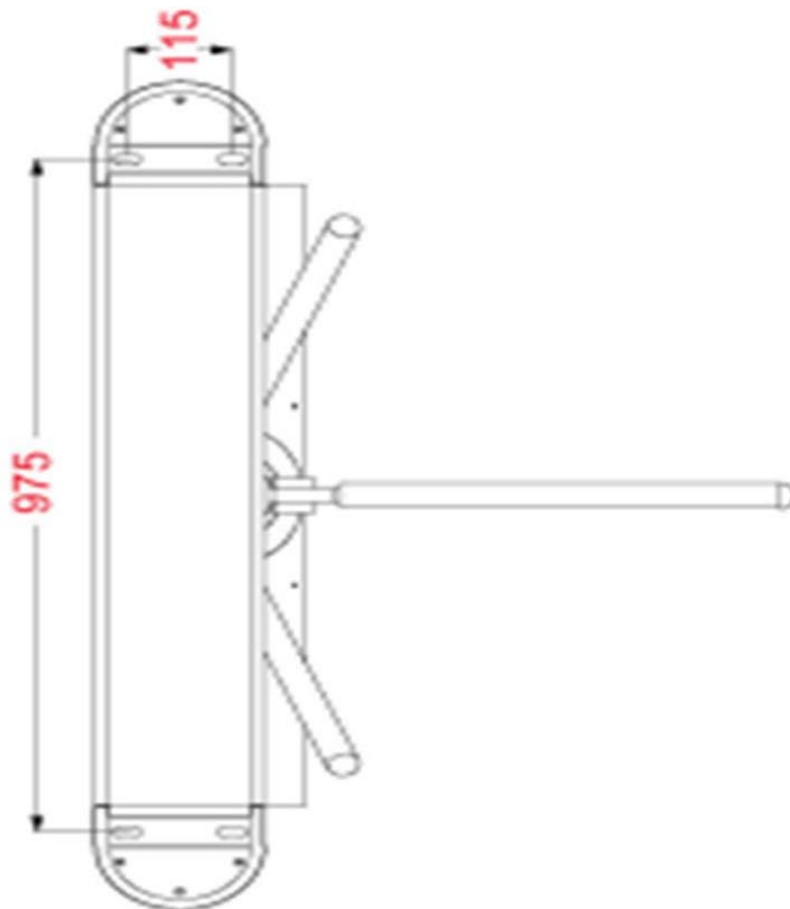
6 Drawings

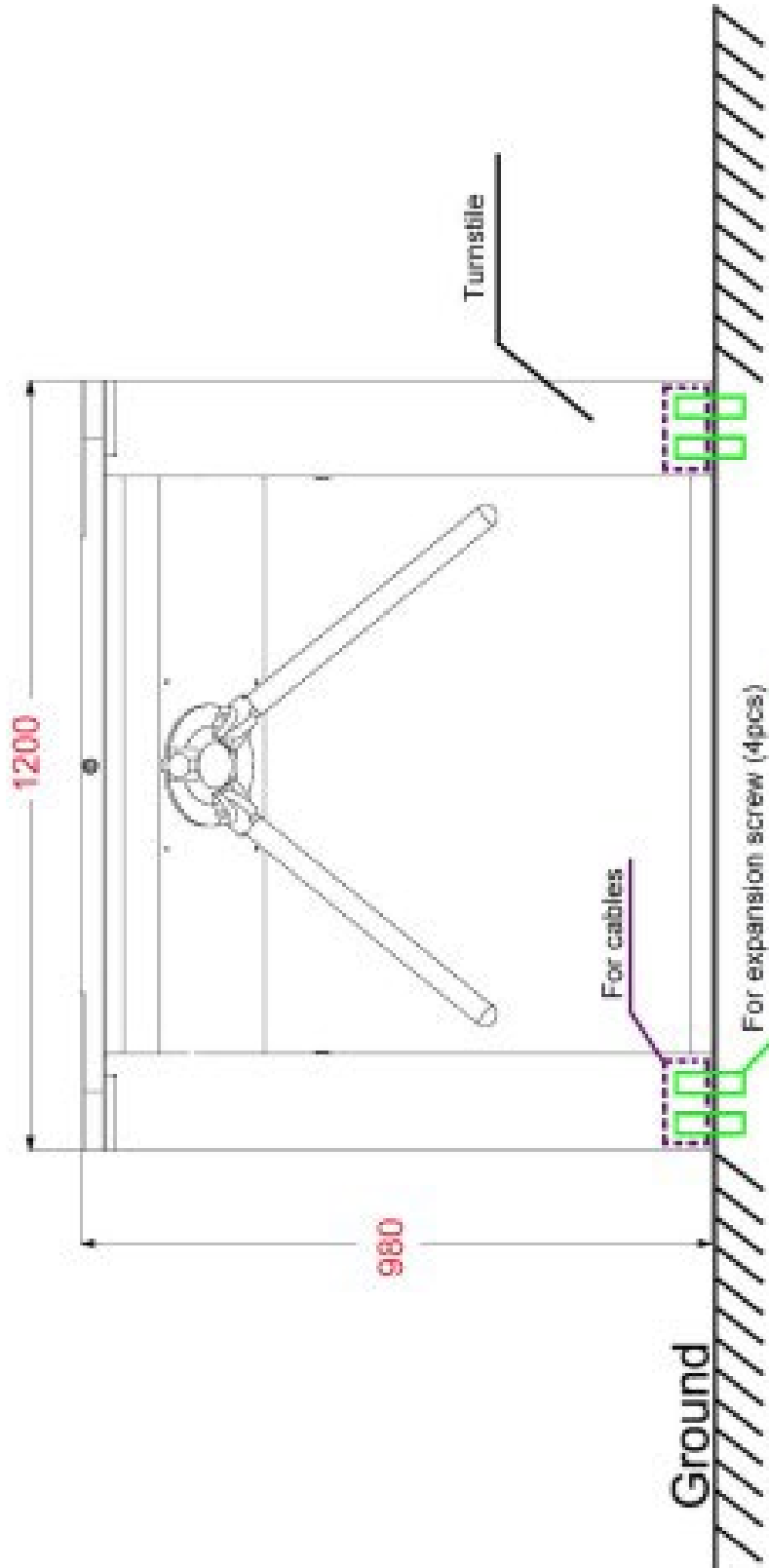

6. Support

iDTRONIC
Ludwig-Reichling-Straße 4
67059 Ludwigshafen am Rhein
helpdesk@idtronic.de