

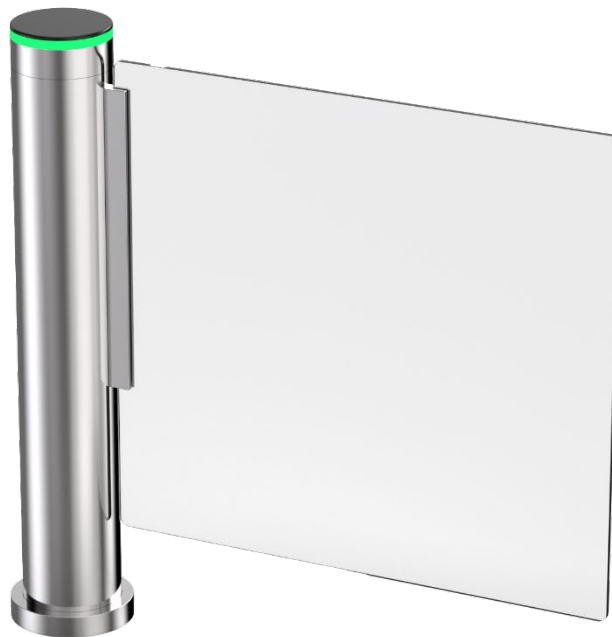

ID Swing Gate 1600

Datum: December 2023

Version: ID Swing Gate 1600



Please read and follow the installation instructions before operating the device and keep the instructions for future reference or for use after troubleshooting.

Table of Contents

1. Product Structure and Operating Principle.....	3
1.1. Electronic Control System of the Swinging Gate.....	3
1.2. Operating Principle of the System	3
2. Installation Instructions.....	4
2.1 Installation suggestion:.....	4
2.2 Glass Panel Installation:.....	4
3. Turnstile Setting and Connections	6
3.1 Setting the gate position	6
3.2 Setting the parameters.....	9
4. Product Maintenance	11
4.1 Maintenance	11
4.2 Tips and Troubleshooting	11
5. Safety Instructions	11
6. Support	12

1. Product Structure and Operating Principle

1.1. Electronic Control System of the Swinging Gate

The electronic control system consists of a card reader, a main control panel, an infrared sensor, a direction indicator panel, an alarm, a transformer, etc.

Card reader (self-built): After reading the information on the card and evaluating and processing it, it sends the signal for application passage (switching signal) to the main control panel.

Main control board: The central control unit of the system, which receives signals from the card reader and infrared sensor, performs logical assessment and processing of these signals, and then issues execution commands to the indicator, motor, counter, and alarm.

Infrared sensor: Detects the position of pedestrians and serves as a safety protection role.

Direction indicator: Displays the current status of the gate and guides pedestrians safely and orderly through the gate.

Alarm: When the system detects unauthorized entry by pedestrians, an alarm is triggered.

1.2. Operating Principle of the System

- a) Turn on the power, and the system enters the operational state after 3 seconds.
- b) When the card reader reads a valid card, a pleasant sound is emitted to inform pedestrians that the card has been successfully read.
- c) The card reader receives signals from the backend database and after comprehensive processing, sends effective control signals to the indicator and the motor, causing the indicator to change into a green arrow passage sign. At the same time, the swing gate emits a setup voice, the main control board controls the motor operation, and the gate opens to allow pedestrians to pass. Otherwise, access is not granted, and the red indicator lights up.
- d) After the pedestrian has passed through the channel according to the direction indicator, the infrared sensor captures the entire process of the pedestrian's passage and continuously sends signals to the main control panel until the pedestrian has completely passed through the channel.

2. Installation Instructions

2.1 Installation suggestion:

Note: Disconnect all circuits during installation.

►► Installation suggestion:

- 1) Cables should be installed in cable channels with a depth of 60 mm, ending between the mounting frames.
- 2) If the swing gate is installed outdoors, consider a greater depth for the cable channels.
- 3) Installation should be done without power connections to the gate.
- 4) After determining the swing gate position, drill the holes and insert anchor bolts or expansion screws (M12). A concrete thickness of at least 60 mm is recommended.
- 5) When installing multiple devices, ensure that they are properly aligned before drilling holes.
- 6) Connect the power line and control line according to the wiring diagram and connect the system grounding cable.
- 7) After successful anchoring and verifying the wiring, turn on the power.
- 8) Upon completion of the installation, check the condition of the grounding wire, the connector assembly for the connecting line, and all moving parts with the device. Ensure that the connection is secure to prevent failures during extended operation. If a screw or part is not tightened firmly, please tighten it.

2.2 Glass Panel Installation:

1. Carefully slide the glass panel between the two wings of the swing gate so that it aligns flush with the holes in the wings.
2. Insert a screw into one of the holes in the swing gate and begin to hand-tighten it to secure the glass panel in place.
3. After all the screws are tightened, inspect the installation to ensure that the glass panel is securely and evenly seated within the swing gate.

Number of screws:	6
Type of screw:	M6 x 10mm
Type of glass:	ESG
Dimensions of the glass:	888mm x 820mm (Width x Height)

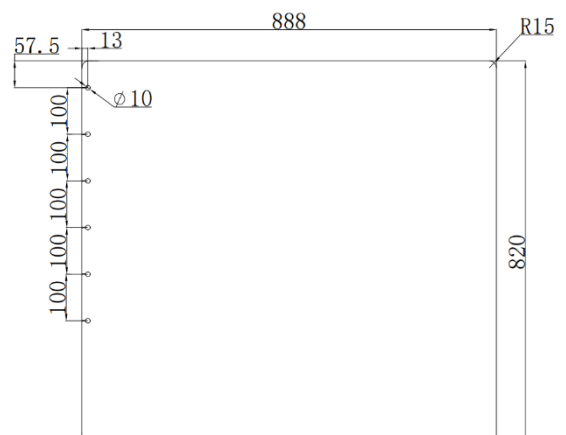

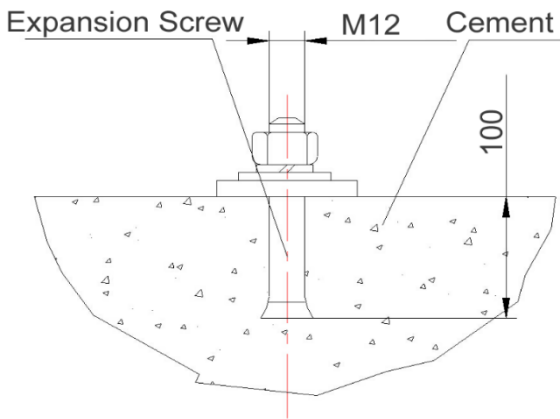

Figure 1

Drawing of the assembled anchor bolts

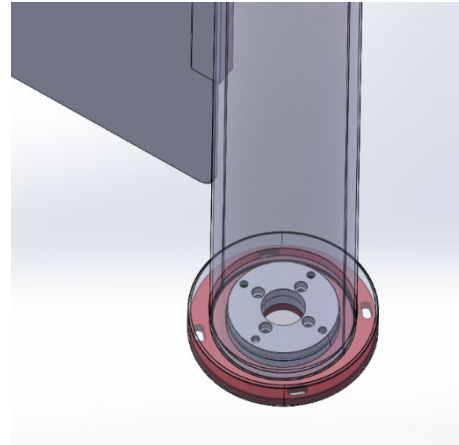

Figure 2

Position of the mounting frame/drill holes

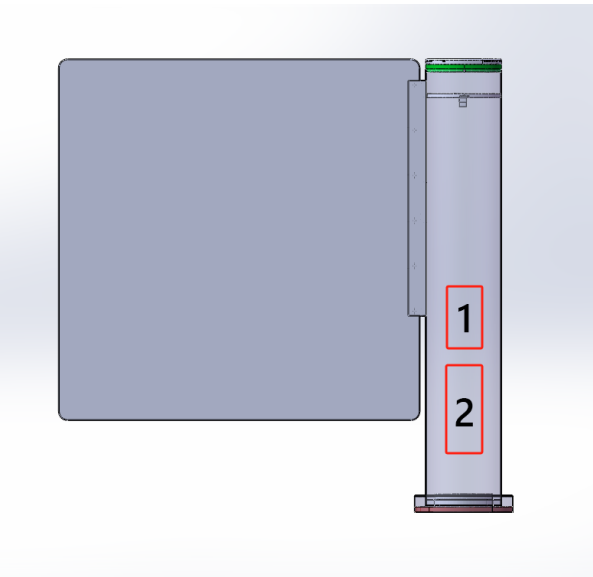

Figure 3 – Component Positions

- 1) Power Supply Unit
- 2) Main Control Board

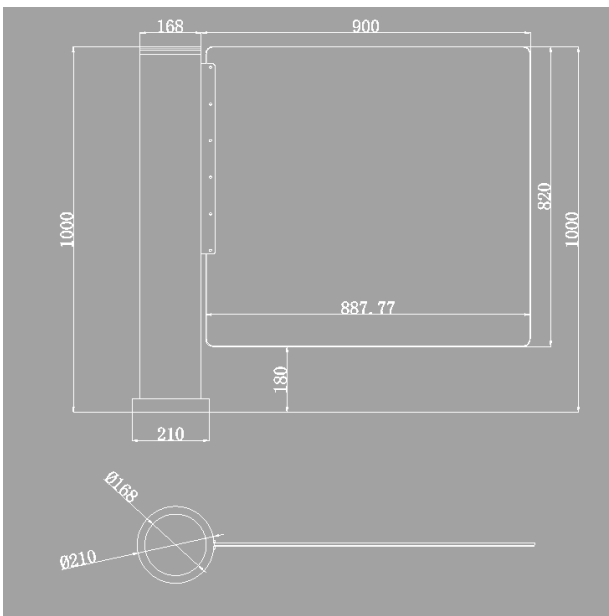

Figure 4 – Product Dimensions

3. Turnstile Setting and Connections

3.1 Setting the gate position

Method for adjusting the position of the door leaf in Swing Gate Mode:

1. Press the INC button (middle button) five times in a row, after which the system will prompt "Please manually adjust the position of the wing gate" and activate the adjustment mode for the door leaf.
2. Slide the door leaf to the target position and hold it still for 3 seconds. The beep sound or the blinking of the corresponding lamp indicates that the current position has been detected.
 - The system will automatically determine, based on the position of the door leaf, whether the current position is left, right, or zero.
3. Slide the door leaf back to the center alignment and hold it still for about 10 seconds. The system will report "Setting completed, welcome to use" and exit the adjustment mode.
 - In most cases, the system automatically adjusts the correct left and right positions. Users only need to set the zero position, align the door leaf, and wait for it to be saved.

Method for adjusting the position of the door leaf in Flap Gate Mode:

1. Press the SET button (middle button) five times in a row, after which the system will prompt "Please manually adjust the position of the wing gate" and activate the adjustment mode for the door leaf.
2. Use the "left open" and "right open" buttons on the main board to move the main motor forward and backward, and use the "left open" and "right open" buttons on the sub-board to move the sub-motor forward and backward. Use these buttons to control the door leaf to move to the target position and stop, hold it still for 3 seconds, and the beep sound or the corresponding blinking of the lamp indicates that the current position has been detected.
 - In most cases, the system automatically adjusts the correct left and right positions.
3. Hold the middle button for more than 2 seconds and then release it to exit the adjustment mode.

Optical Speed Gate Wiring Diagram

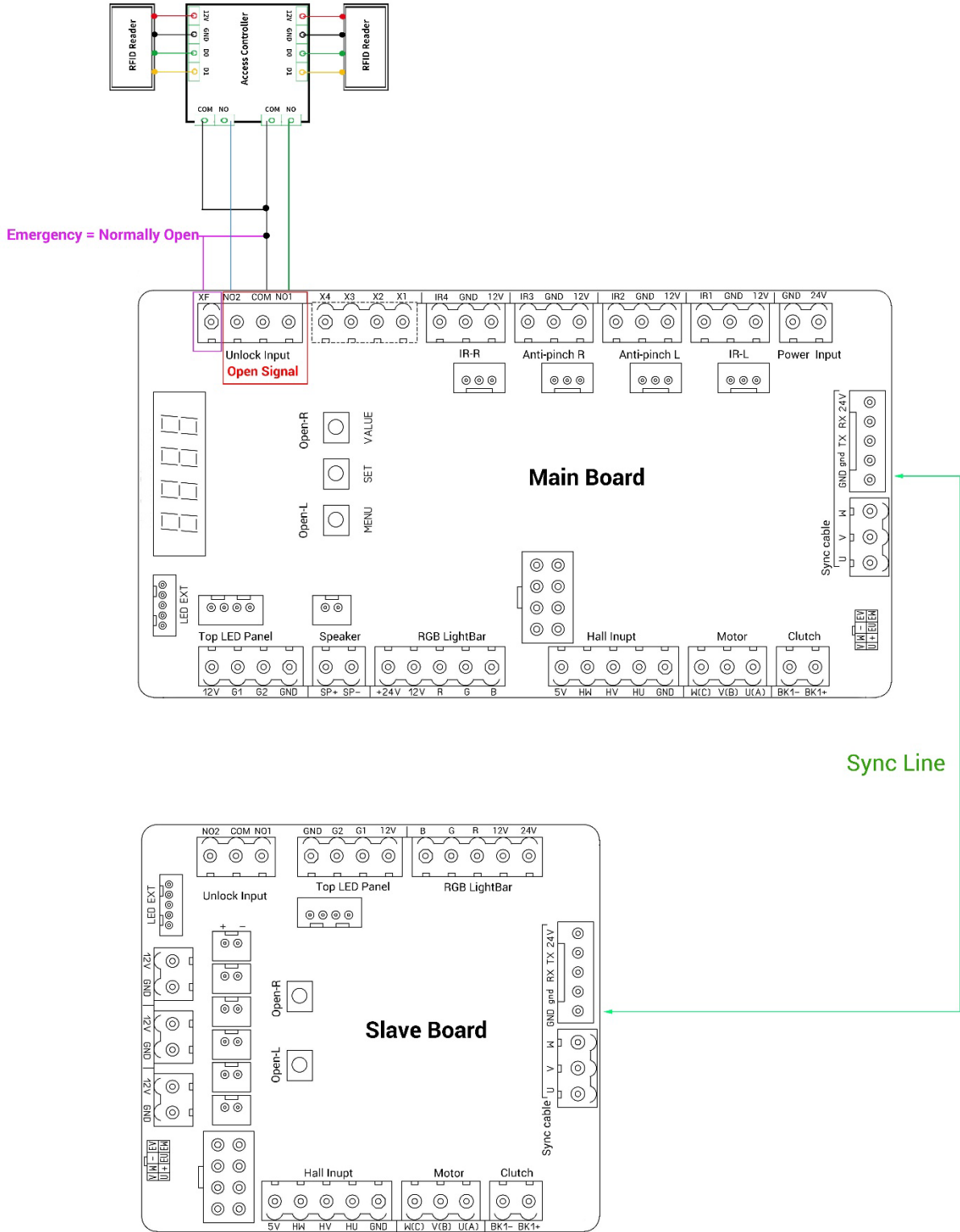

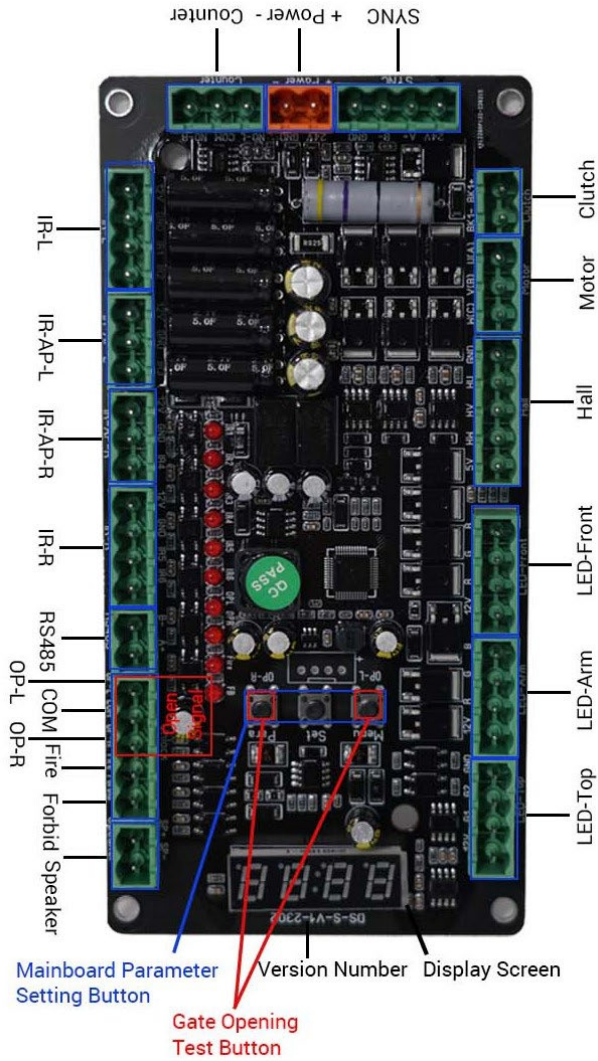

Figure 5 - Description of the Main Board

OP-L = open left

OP-R = open right

Fire = Emergency Exit Connection

Red/Blue marked Buttons = Settings/Testing of Parameters

Power +/- = Power Connection 230V

Counter = Up-/Down Counter for External Use

3.2 Setting the parameters

1. Press and hold the INC button (middle button) until the digital display flashes to access parameter settings.
2. The first and second digit of the digital display indicate the menu, and the third and fourth digit indicate the value. Press the left button to adjust the menu and the right buttons to adjust the value.
3. Hold the button for about 2 seconds, then the digital display will stop blinking.

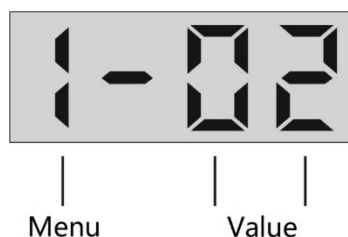

As shown in the figure, the current menu is "Gate Opening Mode," and parameter 02 corresponds to "Left Infrared Free Passage."

Nr.	Function	Area	Standard	Details
1	Gate Opening Mode	1~6	1	1: Standard mode. 2: Left Infrared Free Passage. 3: Right Infrared Free Passage 4: Left and Right Infrared Free Passage 5: Swing Gate Normal Open. 6: Swing Gate Normal Closed. The upper LED display moves accordingly during the settings. The direction of "Infrared Free Passage" is indicated by illuminated arrows
2	Gate Opening Time	1~90	8	Time Unit: Seconds. Use the plus and minus buttons to increase or decrease the time
3	Voice Announcement for Left Gate Opening	0~9	0	0: Thank you; 1: Please pass; 2: Goodbye; 3: Welcome; 4: Welcome again; 5: Have a safe journey; 6: Have a pleasant trip; 7: Wear a safety helmet; 8: Verification successful; 9: Mute.
4	Voice Announcement for Right Gate Opening	0~9	3	s.o.
5	Voice Volume	1~9	5	Plus and minus buttons for adjusting the voice volume of announcements
6	Main Motor Speed	1~25	13	If the combined gear ratio of the motor and motion mechanism is too low or too high, this setting must be adjusted
7	Main Motor RPM (Rounds Per Minute)	1~25	13	

9	Delay Interval	1~30	10	This parameter is set for smooth gate opening/closing
				If the door leaf does not come to a smooth stop and creeps slowly, you should decrease the parameter
				If the door leaf suddenly stops and wobbles strongly, you should increase the parameter
12	Gate Control Closure	0~9	2	0: Start closing during ongoing passage 1: Start closing at the end of the passage
				2: Start closing after the passage
				3-9: Additional delay (n-2 seconds) after completion of the passage
13	Single Motor Operation	0~1	0	0: Dual motor operation (for passage in both directions). 1: Single motor operation (for passage in one direction).
15	Obstacle Detection, Infrared Anti-Pinch Reversal	0~1	1	0: Obstacle detection => Gate remains in position. 1: Obstacle detection => Gate opens fully again.
16	Mechanical Anti-Pinch Sensitivity	1~9	5	The higher the value, the higher the sensitivity
19	Gate Shutdown Opening Direction	0~2	2	0: Power Failure Opening to the left
				1: Power Failure Opening to the right
				2: The system automatically selects the power failure gate opening direction based on the current situation
				The gate opening direction can be compared to the arrow direction on the upper indicator plate
22	Left and right effective infrared signal delay	1~9	5	Time = Parameter * 20 milliseconds (default value 100ms)
27	Priority Setting for Anti-Pinch Protection	0~1	0	0: Fast passage mode, priority for gate opening, infrared anti-pinch protection is deactivated during the gate opening process.
				1: Safe passage mode, priority on anti-pinch protection, infrared anti-pinch protection applies during the gate opening process.
32	Main Motor Sliding Compensation	0~9	0	If the gate cannot return to the starting position immediately after the self-check is completed, the sliding compensation can be increased accordingly.
33	Slave Motor Sliding Compensation	0~9	0	

4. Product Maintenance

4.1 Maintenance

- To avoid the risk of an electric shock, always turn off the device before inspecting its internal components.
- We recommend inspecting/checking the swing gate regularly to ensure proper operation.
- The material is made of stainless steel; please use appropriate cleaning agents.

4.2 Tips and Troubleshooting

1. If the arm does not open after swiping the card, please double-check that all wires are properly connected and that the card is recognized as "valid" by our backend system.
2. If the display does not light up or shows an incorrect direction, please contact us to check for faulty wiring.
3. If the swing gate does not open automatically after turning off the power, the battery may be defective - please contact us for a replacement.
4. If the arms open normally but do not close, check the infrared sensor to ensure it fits well and is clean.

5. Safety Instructions

- 1) Turn off the power before installation, maintenance or repair.
- 2) Do not alter the internal wiring without prior consultation.
- 3) For your own safety, have changes to the wiring or repairs to the electronic parts of the gate performed only by professionals.
- 4) Do not use the built-in power supply to connect external devices unless instructed to do so by an iDTRONIC employee.
- 5) Do not operate the swing gate during thunderstorms and lightning to avoid damage to the electrical components of the swing gate.

6. Support

iDTRONIC

**Ludwig-Reichling-Straße 4
67059 Ludwigshafen am Rhein
helpdesk@idtronic.de**