



Security Gate

ID GATE 5800 DUAL

PRODUCT DESCRIPTION

The ID GATE 5800 DUAL is a modern security gate designed for efficient access control in demanding indoor environments. It is ideally suited for high-traffic locations such as airports, office buildings, or public institutions, and offers maximum security and efficiency through its intelligent sensor technology and robust construction.

DIMENSIONS

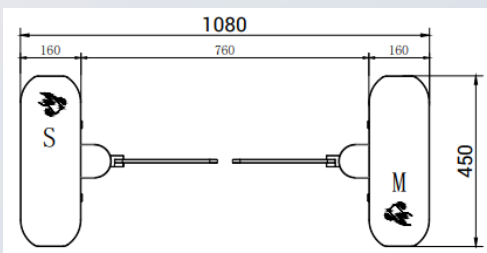
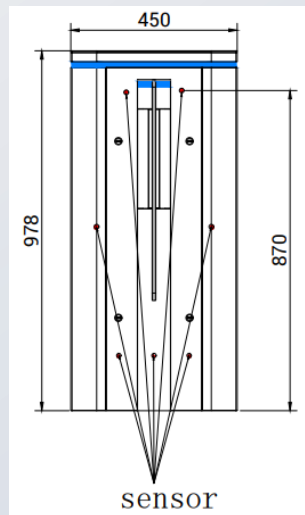
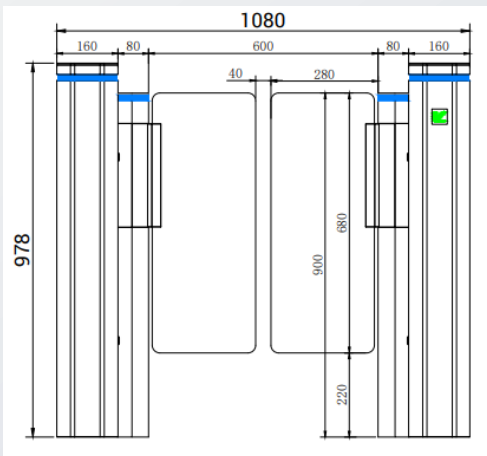

HIGHLIGHTS

- Efficient access control with high operational reliability
- Extremely fast opening and closing time of 0.1 seconds
- 7 integrated sensors for precise person detection
- RGB lighting and LED indicators for directional guidance
- Transparent swing doors made of acrylic or tempered glass
- Automatic door opening in case of power failure
- High-performance speed gate for indoor environments

Accessories (Optional)

- iDTRONIC RFID Built-In R840
- QR Code/ RFID Combi-Reader ID 1500/1200
- Remote Control (Wired / Wireless)
- Integration of Third-Party Readers (z.B. MIFARE, LEGIC, EM, HID etc.)

TECHNICAL DATA

SPECIFICATION

Dimensionen	978 x 1920 x 450mm
Material	Steel - painted varnished Or stainless steel
Power Supply	AC220V / 110V, 50/60Hz
Operating Voltage	24V DC
Passage Frequency	55 people per minute
Emergency Mechanism	Automatically opens the arms when power is turned off
Interface	Relaisignal, RS485
Sensors	7 sensors per column
Operating Location	Indoor
Protection Class	IP54
Operating Temperature	-20°C up to +75°C
Humidity	≤90%
Scope of Delivery	<ul style="list-style-type: none"> • Security gate made of stainless steel • Swing doors made of acrylic / tempered glass • Anchor bolts (M12) + nuts • Wired remote control (for testing purposes only) • Cleaning kit

DIMENSIONEN

DIMENSIONEN

Transparent acrylic / Tempered glass	<p>Standard:</p> <ul style="list-style-type: none"> • 275x650 mm (600mm Passage width; 900mm Height) • 425x650 mm (900mm Passage width; 900mm Height) • 275x1020 mm (600mm Passage width; 1300mm Height) • 425x1020 mm (900mm Passage width; 1300mm Height)
---	---

ORDER CODES

DESCRIPTION

ID Gate 5800 Dual	<ul style="list-style-type: none"> • R-TS-IDG-5800-D
-------------------	---

PRODUKTBILDER

